

参考用图	√
开模用图	
生产用图	

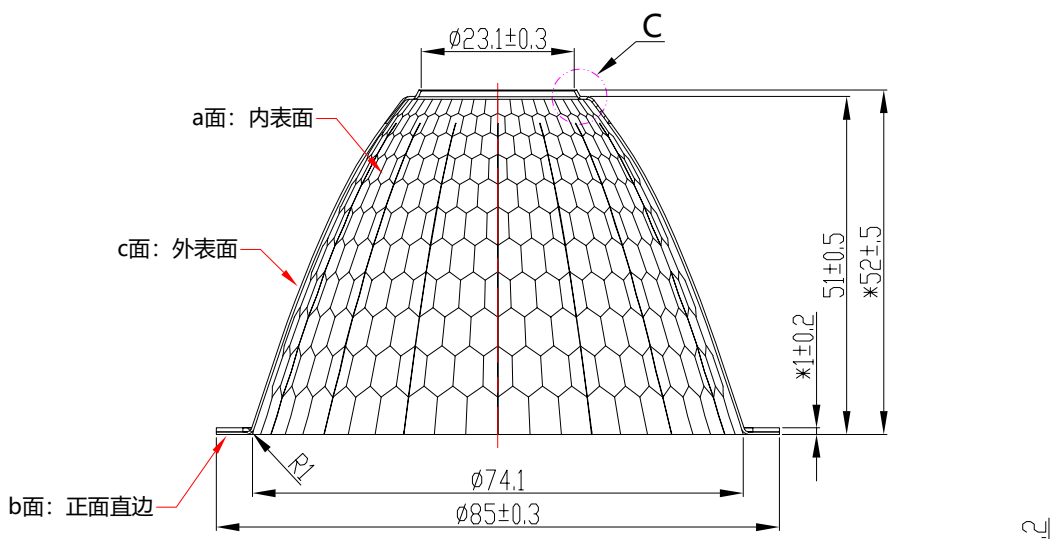

A - A

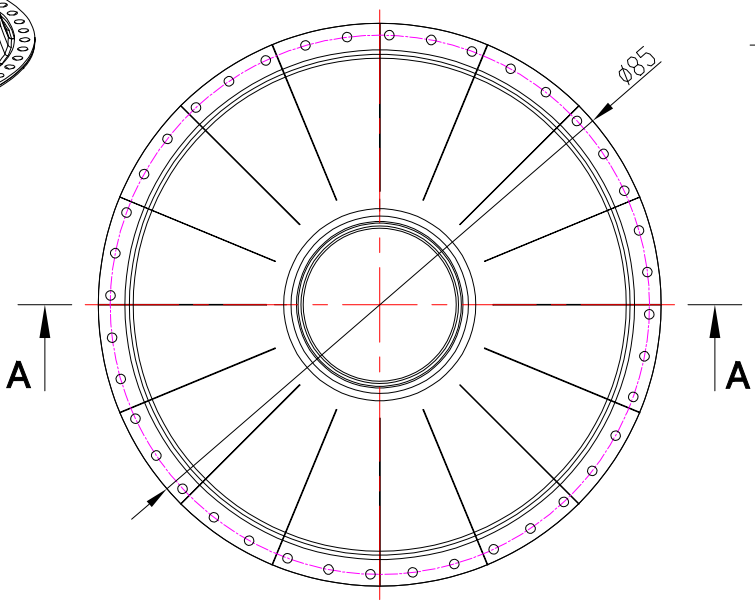
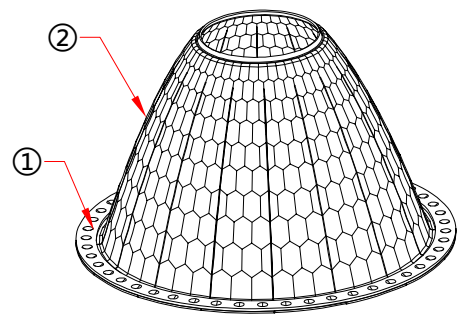
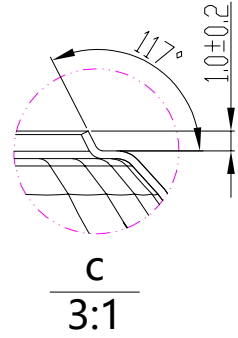

Light Source	CITIZEN CLU038
PlasticHolder	92.70.412.00
Metal Adaptor	
Design Angle	$15^\circ \pm 3^\circ$
Measured Angle	14.8°
Efficiency	

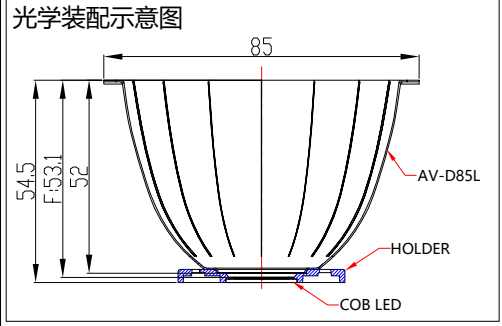

- 技术要求:
- 1.材质: T=0.4mm 高反射率铝(镜面).
 - 2.表面处理: 氧化铝+PVD镀银.
 - 3."*"标记为重点控制尺寸.
 - 4.产品未注圆角与拔模斜度按3D.
 - 5.产品外观按《N-SIP-QA-04 铝反光杯检验标准》.

PRODUCT BOM				
NO.	PRODUCT NAME	PRODUCT CODE	QUANTITY	MATERIAL/FINISH
①	铝圈	97.76.693.00	1	T=0.6mm 1060AL H22
②	3-2500-A		1	T=0.4mm High reflectivity aluminum(Mirror surface)

标记	处数	更改内容	签名	更改日期
MARK	NO.OF MODIF.	MODIFICATIONS	SIGNED BY	MODIF. DATE
设计		制图	比例	1:1
DESIGNER		DRAWN BY	SCALE	
工艺		审核	视角	
TECHNICAN		CHECKED BY	1st ANGLE PROJECTION	
批准		日期	页数	SHEET 1 OF 1
APPROVED BY		DATE(DD-MM-YYYY)	PAGE	
		27-12-2024		

DIMENSION TOLERANCE TABLE (UNLESS OTHERWISE STATED)						
> 0-5	> 5-30	> 30-90	> 90-150	> 150-250	> 250-400	> 400-700
±0.15	±0.2	±0.4	±0.5	±0.8	±1.5	±2

PUNCH TOLERANCE TABLE (UNLESS OTHERWISE STATED) (ANGLE)					
> 0-10	> 10-50	> 50-120	> 120-250	> 250-360	
±1°	±0.5°	±0.3°	±0.2°	±0.166°	

		版本	V1.0
		VERSIONS	
产品编码	PRODUCT CODE	91.03.2853.001	
产品名称	PRODUCT NAME	3-2853-L2	
客户代号	CUSTOMER ID	NT	
客户编号	CUSTOMER CODE	AV-D85L切合反光罩-15D	

部件产品图
COMPONENT PRODUCT DRAWING

单位
UNIT
mm